

STELLA UTOPIA™ EM™

USER MANUAL



SUMMARY

	pages
STELLA UTOPIA	4
WARNING!	5
INSTALLATION	6
CONNECTION	8
FINE TUNING	10
SPECIFICATIONS	21
MEMO	22
INTERNATIONAL GUARANTEE	25

STELLA UTOPIA™ EM™

Thank you for choosing Focal loudspeakers. We are pleased to share with you our philosophy: “the Spirit of Sound”. These high performance speakers feature the latest technical developments from Focal in terms of speaker design, whether it is for high fidelity or home theater systems. In order to (make the most of these speakers) enjoy the maximum of their performance, we advise you to read this user’s manual and to keep it carefully so that you can consult it later.

The Focal-JMlab guarantee only applies if the enclosed guarantee card is returned to us within 10 days of purchase.

Running-in period

The drivers used in the loudspeaker are complex mechanical devices and require run-in period before they deliver their best performance. They must get adapted to the temperature and humidity conditions of their environment. This breaking-in period depends on the encountered conditions and can last several weeks. In order to shorten this period, we advise you to let your loudspeakers operate for about twenty hours at medium level, playing standard musical programmes, but with a large amount of bass.

Once the components of the loud-speakers are completely stabilized, it is possible to enjoy the real performance of your loudspeakers.

User precautions

All the products are lacquered in order to offer a resistant cabinet surface and to make the upkeep easy. We recommend the use of a dry cloth to dust your pair of loudspeakers. If the loudspeaker is stained, then use a damp cloth.

Never use any solvents, detergents, alcohol or corrosive products, scrappers or scouring powder to clean the surface of the loudspeaker. Avoid placing the loudspeakers near a heat source.

Accessories

Floorstanding loud-speaker systems include four decoupling spikes and four butyl cone and could be screwed, if necessary, into the four metal inserts situated on the base of the loudspeaker. These spikes ensure a better stability for floorstanding speakers, particularly if the floor is not perfectly flat and smooth. This stability improves clarity in bass and midrange by decoupling the system from the floor and thus reducing floor-born resonances. This required stability allows the energy delivered by the woofer cone to be integrally converted into sound. The enclosed spikes are adjustable in height. When the use of the spikes proves to be necessary, we advise you to place a piece of metal (such as a coin) between the floor and the spike in order to avoid scratching a tiled floor.



WARNING !

Focal-JMlab, incorporated company with a capital of 527 000 euros, which registered office is situated in 108, rue de l'Avenir, BP 374 42353 La Talaudière, registered at the RCS of St Etienne under the number 309 645 521 000 76.

The loudspeakers use a pure Beryllium inverted dome tweeter that extends the bandwidth up to 40kHz.

Because of the Beryllium potential dangerousness, the material that constitutes the tweeter, some safety instructions described below must be followed by the user of the loudspeakers in order to avoid any risk of this material absorption.

However, the risks are extremely limited in its solid form, as the product dangerousness is linked to the inhalation, absorption or contact of vapours or micro-particles.

1. Safety instructions

The Beryllium dome must never be in contact with abrasive material.

You must avoid any contact with the skin or the eyes, any inhalation or ingestion of the whole or a part of the Beryllium dome. The manufacturer underlines that the Beryllium absorption by respiratory, digestive tracts or skin can lead to serious physical troubles, because of its high toxicity for man.

We then recommend to the loudspeaker users to carefully keep the tweeter protection grille in place. If the protection grille is removed, the user will have to carefully replace this grille after use.

Generally speaking, children must be kept away from loudspeakers and especially from the Beryllium dome.

2. In case of dome damaging

If the Beryllium dome is damaged in any possible way, you must cover it as soon as possible on all its surface with the supplied protection adhesive tape. We recommend that you contact the retailer so that a competent department will take off and replace the tweeter.

If the dome is broken, the possible Beryllium particles must be carefully collected with the supplied protection adhesive tape and then be placed in a hermetically sealed plastic bag. It will be sent with the loudspeaker to the retailer.

In case of absorption by skin, eye projection or in case of inhalation or ingestion of Beryllium, see a doctor.

3. End of life for loudspeakers - Information

At the end of the loudspeaker life, you must not throw this product in the environment, but you must take it to an adapted recycling center.

For more information, please contact us directly to the following address: beryllium@focal-fr.com.

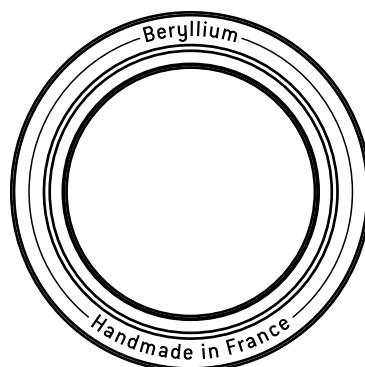

INSTALLATION

Positioning

The loudspeakers have been engineered to deliver the most faithful sound reproduction, whether they are used for music or home cinema. In order to enhance their performance, to guarantee a high quality of listening, sound image and tone balance, it is important to note the following basic rules.

The listening area must be located at the summit of an equilateral triangle whose two other points of insertion are determined by the position of each speaker. Nevertheless it is possible to modify these distances to find an ideal compromise according to the particular disposition of the room (*fig. A*).

Each loudspeaker must be placed at the same height and on the same floor plan. The tweeter should be at the same height as the listener's ear, when the listener is in their usual listening area (*fig. B*).

Avoid placing the loudspeakers too close to the room's corners or walls. This will induce some unwanted room resonance and artificially increase bass response. On the contrary, if the bass level proves to be insufficient, it is possible to move the speakers closer to the walls to adjust the bass level (*fig. C*).

Optimization

To please the perfectionists, we shall give an optimum positioning formula: if **A** is the distance from the boomer centre to the closest wall (floor or wall), **B** the intermediate distance and **C** the longest distance ($A < B < C$), the relation $B^2 = AC$ determines the ideal position of the speakers (*fig. D*).

• Example 1:

The woofer centre of the Stella Utopia EM is 80cm (31^{1/2}") from the floor ($C=80$ cm), standing 50cm (20") from the back wall ($B=50$ cm), the side wall will be ideally 63cm (24^{1/2}") ($A = \sqrt{BC} / A = 63$ cm).

Connections

Input sockets ensure reliable multipurpose connections for stripped cables as well as for plugs.

It is imperative to respect the connector polarity of both the loudspeaker and amplifier. The positive terminal "+" must be connected to the corresponding (matching) amplifier's terminal and the negative terminal "-" to the negative terminal. Stereo image, soundstaging and bass perception would be seriously compromised if these conditions were not respected.

INSTALLATION

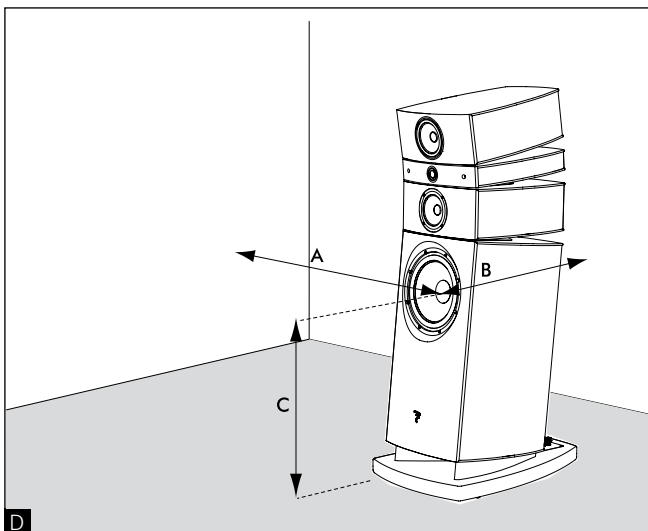
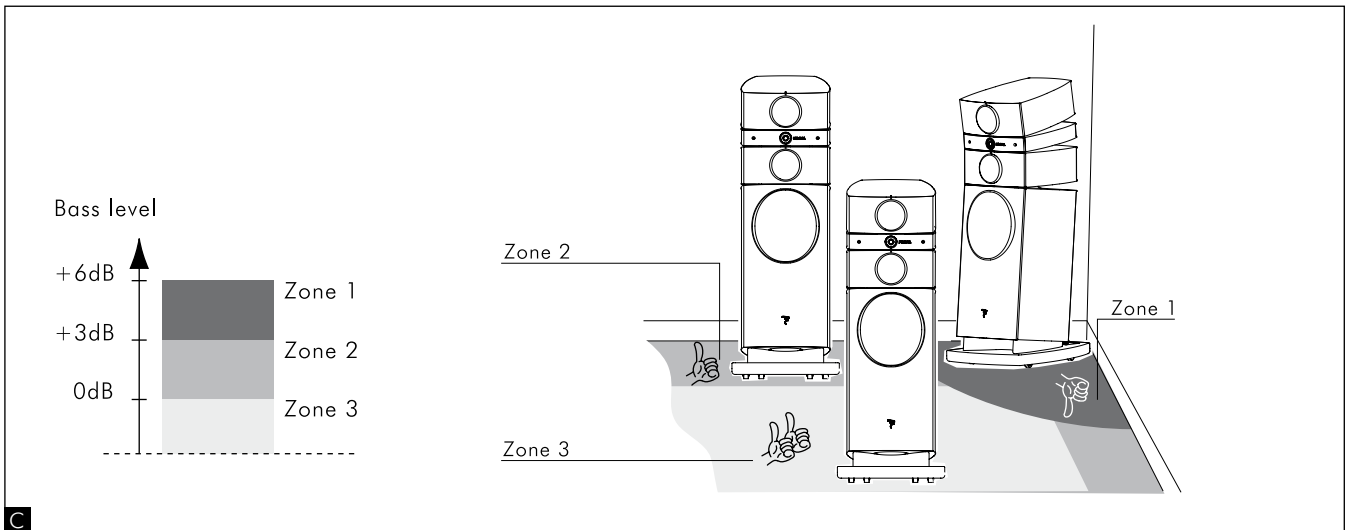
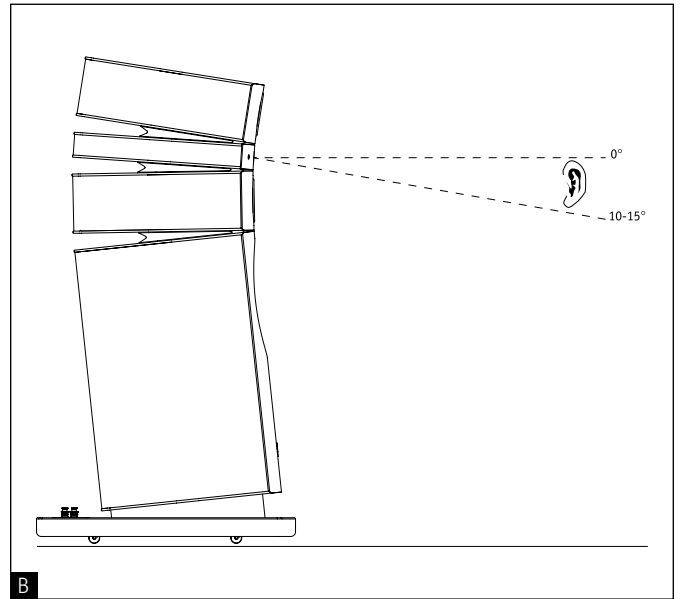
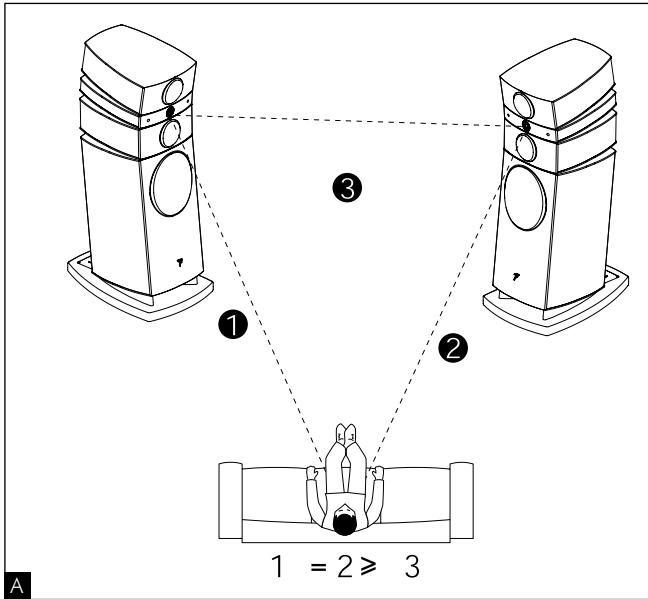

CONNECTION

Power supply connection

Connect the power supply on the Stella Utopia EM.

Switch ON (Autopower mode). The power supply automatically switches on or off when an audio signal is present or not.



Warning: Do not use without continuous current power supply.

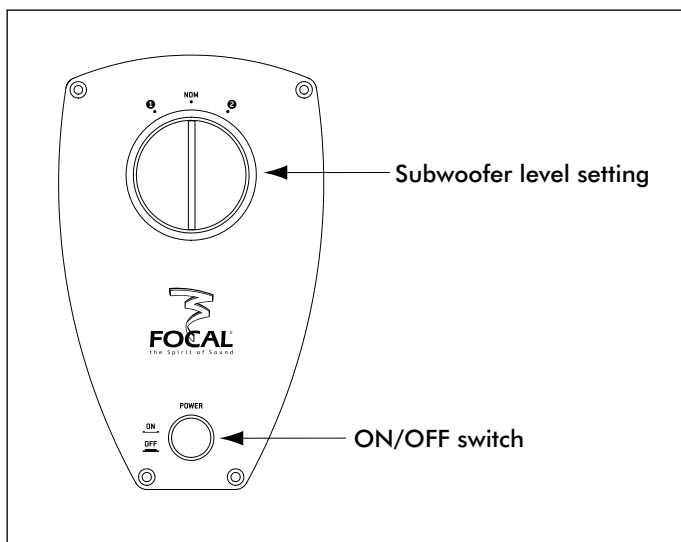
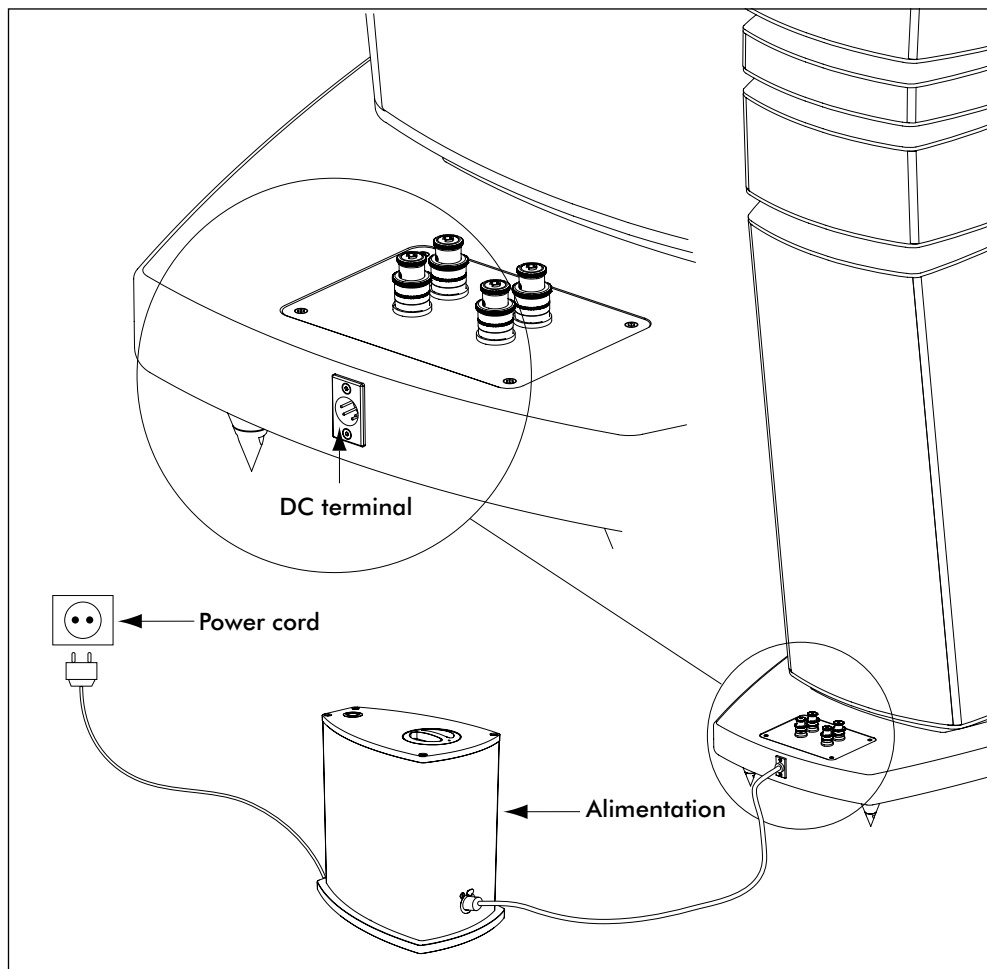

CONNECTION

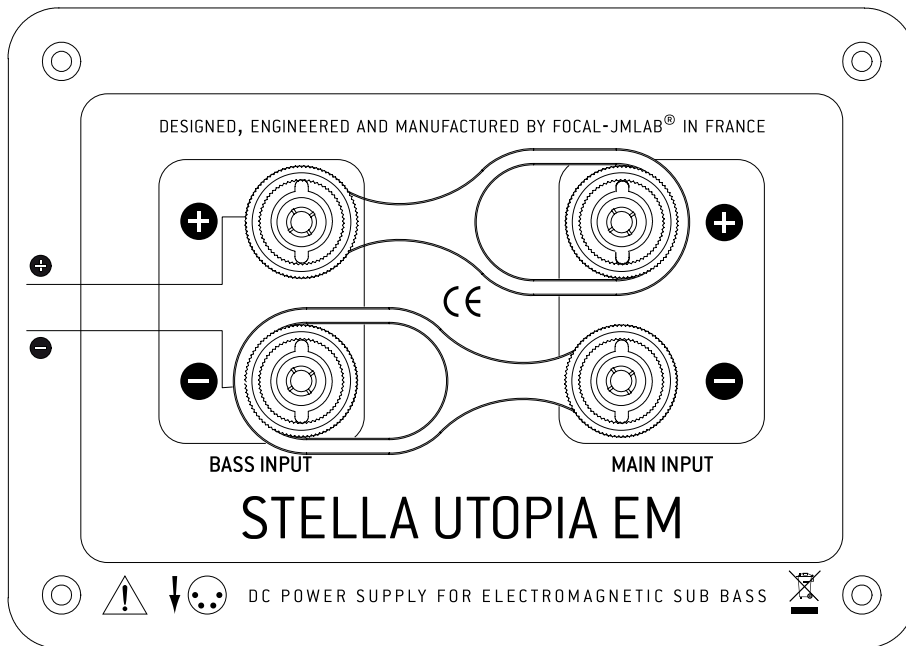

Mono-amplification

Use the supplied straps and connect the inputs as indicated.

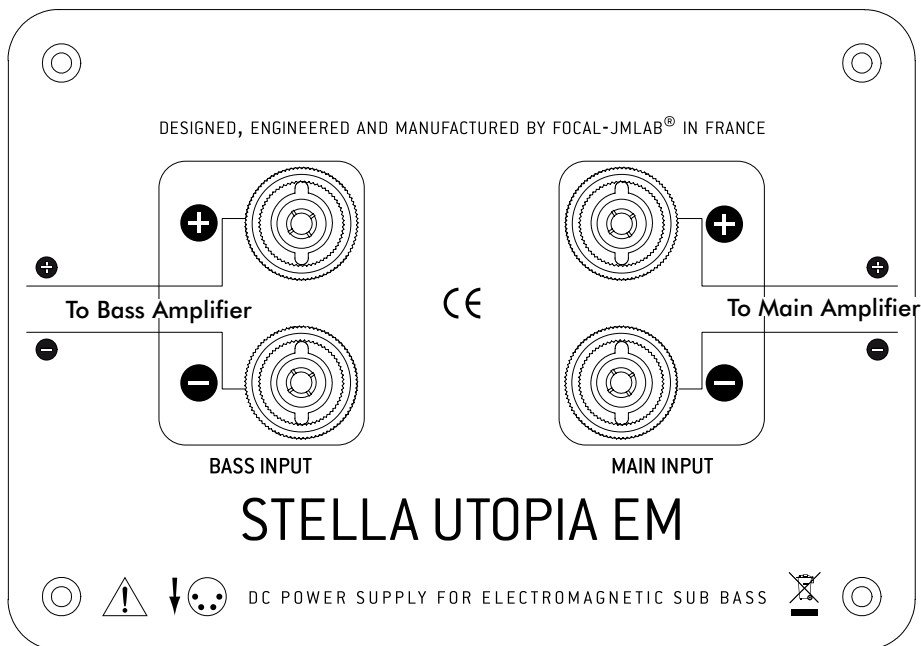

Bi-wiring and bi-amplification

Do not use the straps. Connect each cable or each amplifier on the BASS and MAIN inputs.

FINE TUNING

OPC + settings

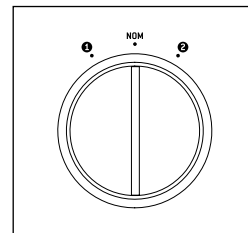
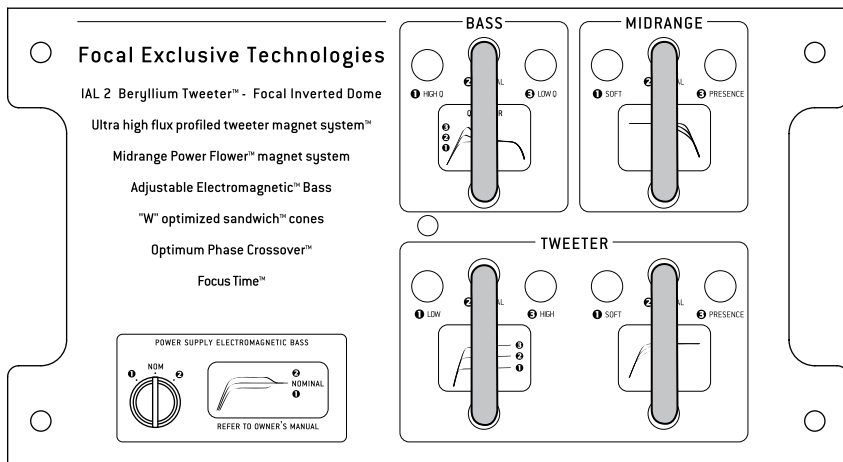

Rotary switch of the EM power supply in nominal position.

Bass section: power supply setting

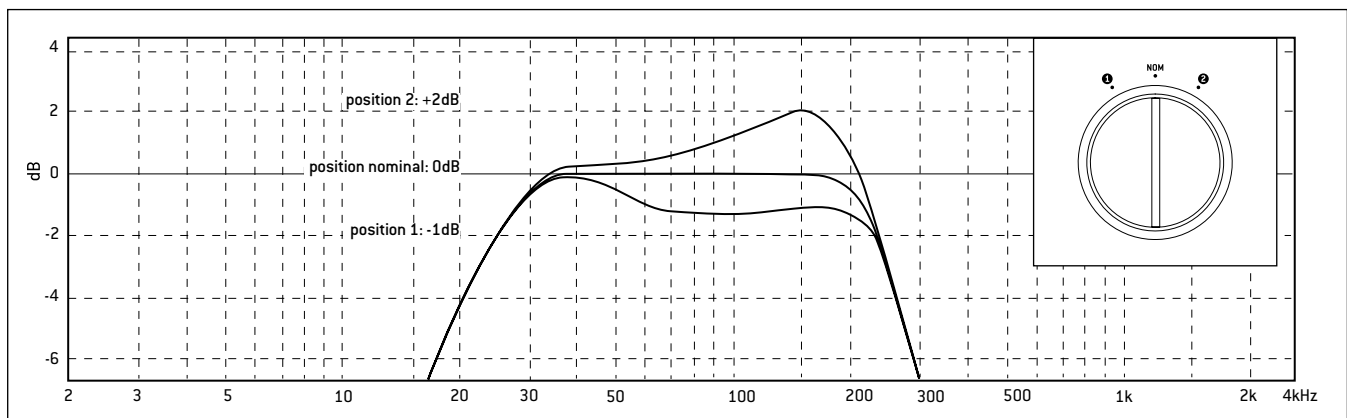

Bass section: quality factor setting

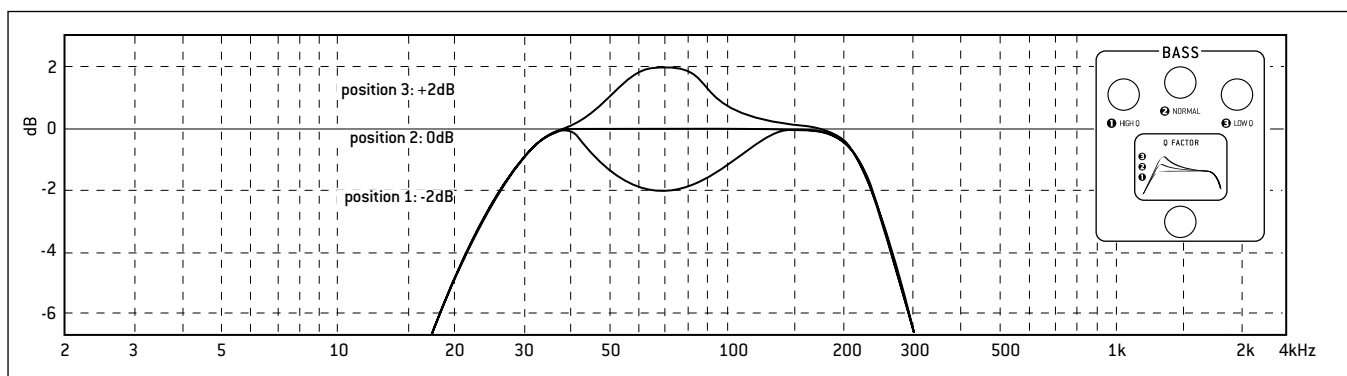

Midrange section: slope settings

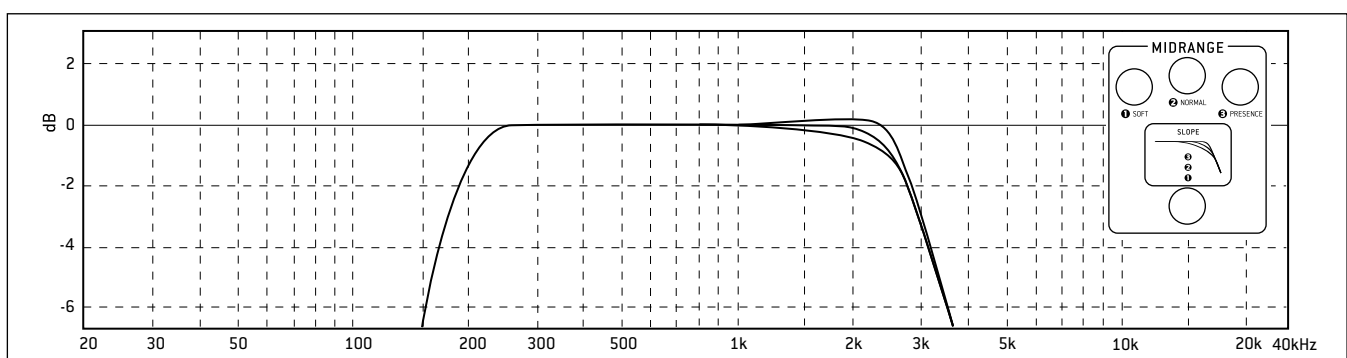

FINE TUNING

Tweeter section: slope settings

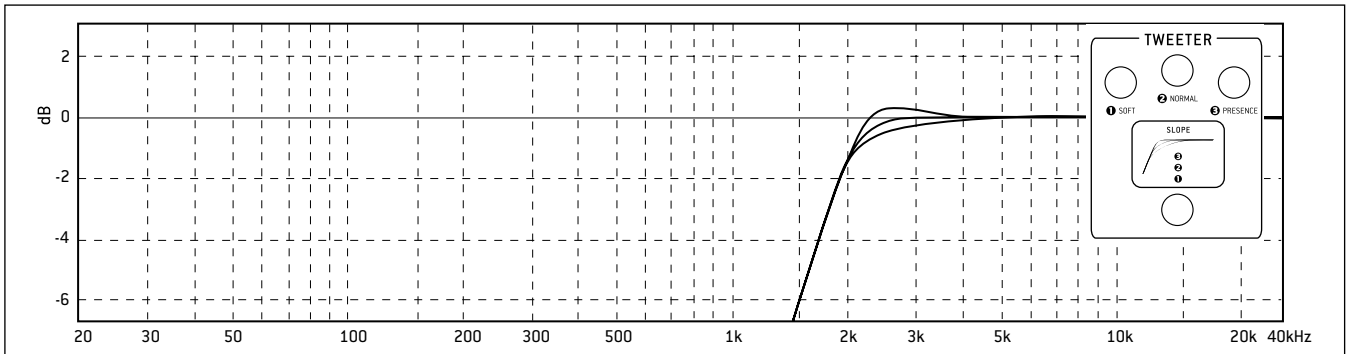

Tweeter section: level settings

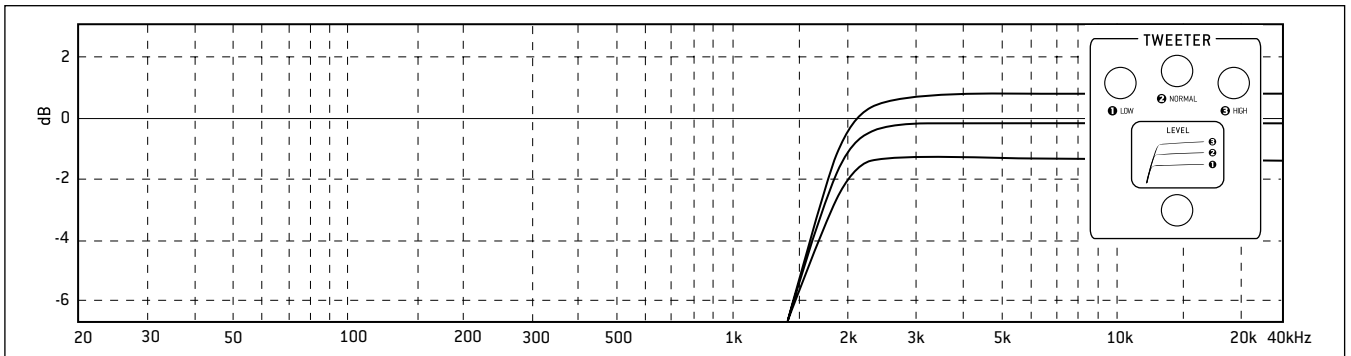

FINE TUNING

The global speaker: linear nominal response

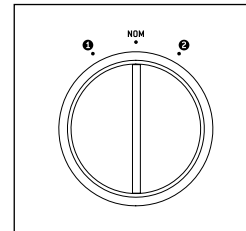
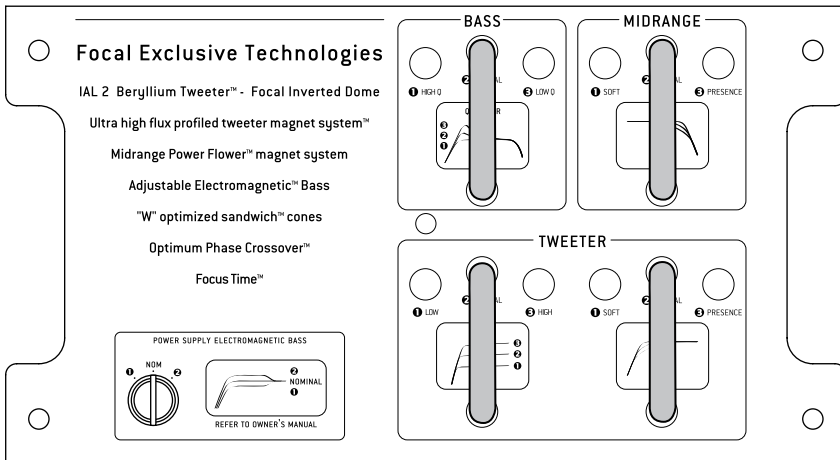

Rotary switch of the EM power supply in nominal position.

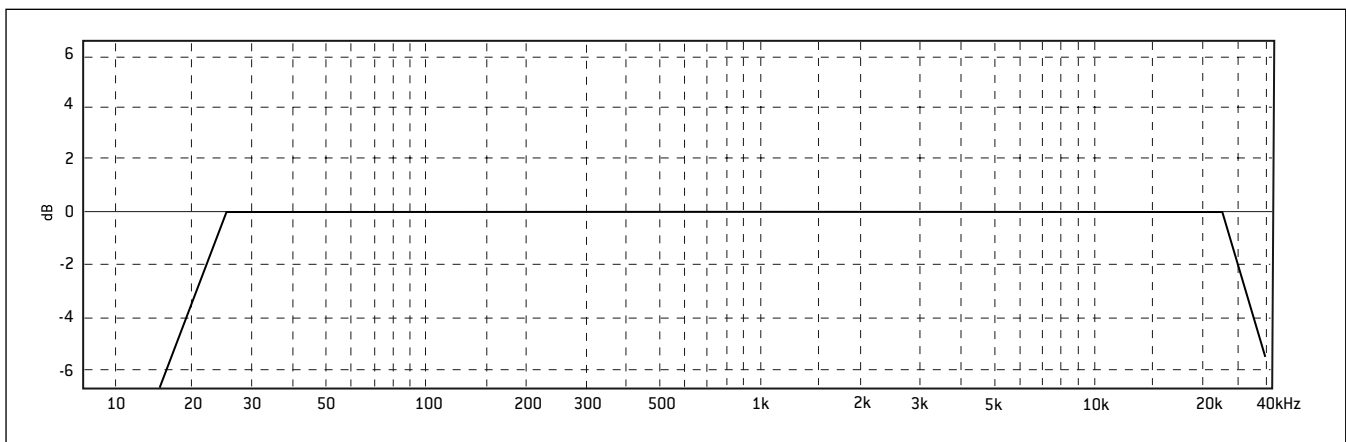

Response with all the settings in nominal position.

Linear setting for ideal conditions:

- Slightly absorbing room with light curtains, few windows, wooden floor with a thick carpet between loudspeakers and listener, some plants, a fabric sofa (or maybe leather with extra fabric seats).
- Neutral electronics, sounding neither too clear nor too muffled.

FINE TUNING

Bass section: power supply setting

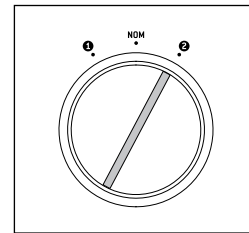
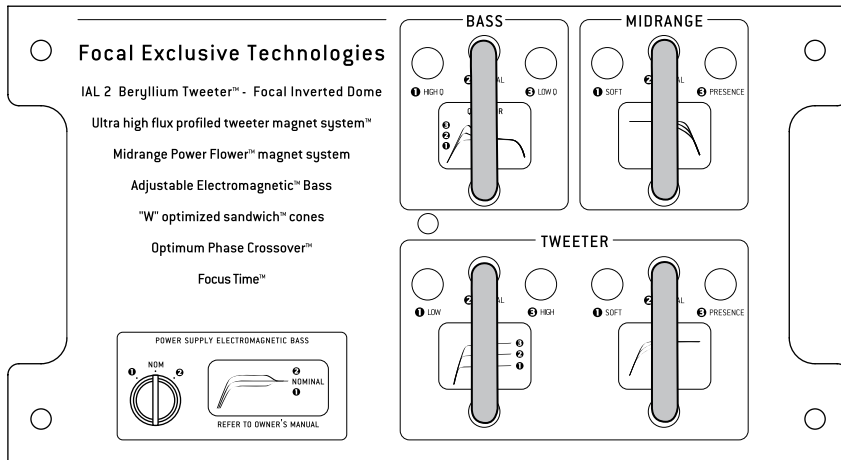

Rotary switch of the EM power supply.

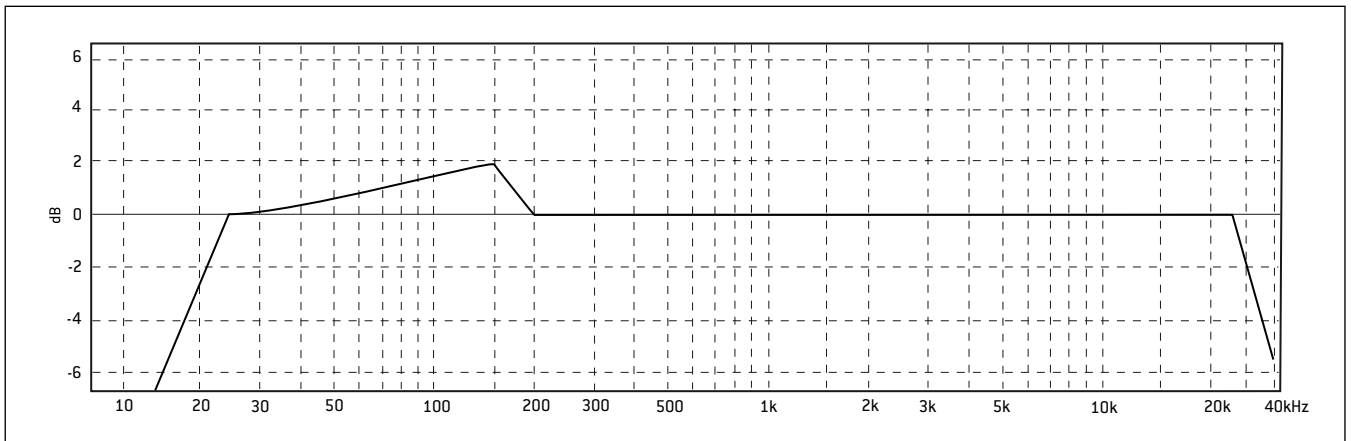

Obtained response in positions 2.

Setting for:

- A room with excellent acoustics (as in previous page) but with large or very large dimensions.
- Electronics lacking bass.

FINE TUNING

Bass section: power supply setting

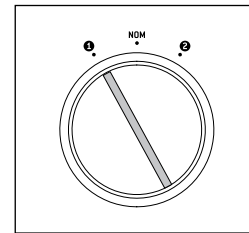
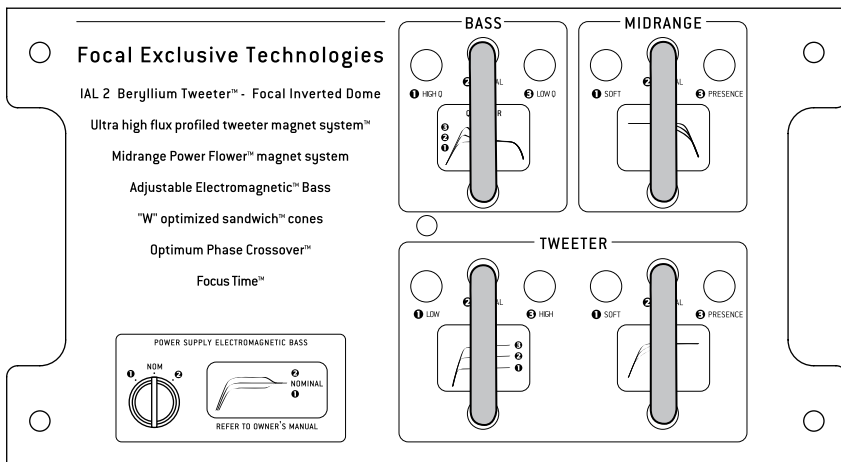

Rotary switch of the EM power supply.

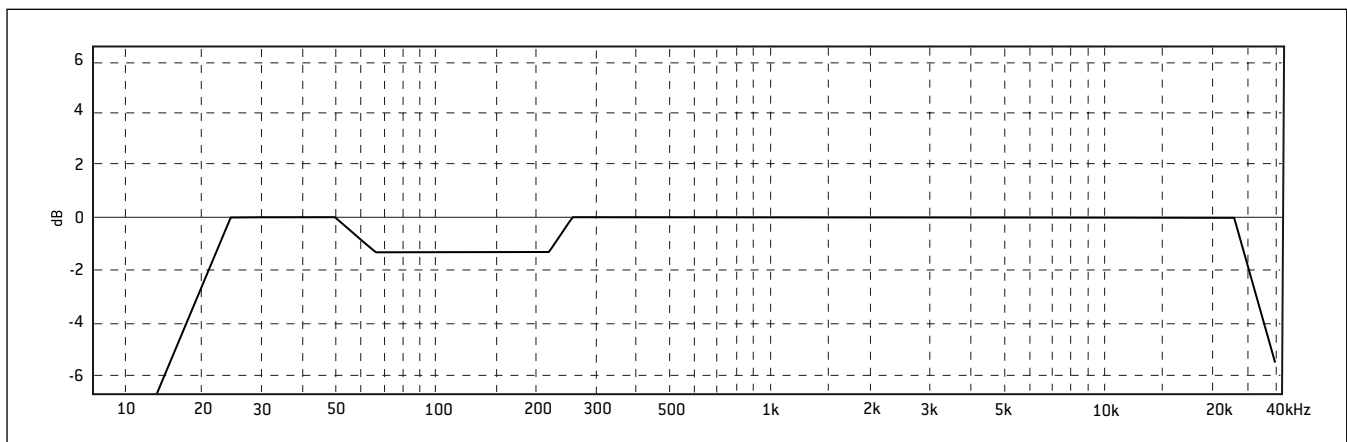

Obtained response in position 1.

Setting for:

- A room with excellent acoustics (as in previous page) but with small or average dimensions.
- A loudspeaker placed too close from an angle or a wall.
- Electronics which pushes up the bass.

FINE TUNING

Bass section: quality factor setting (damping factor)

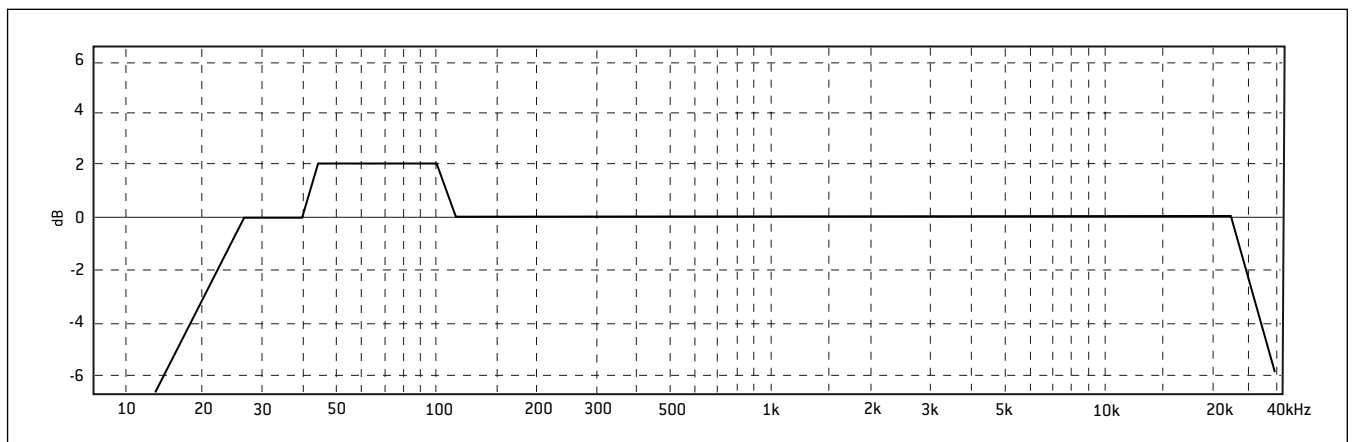
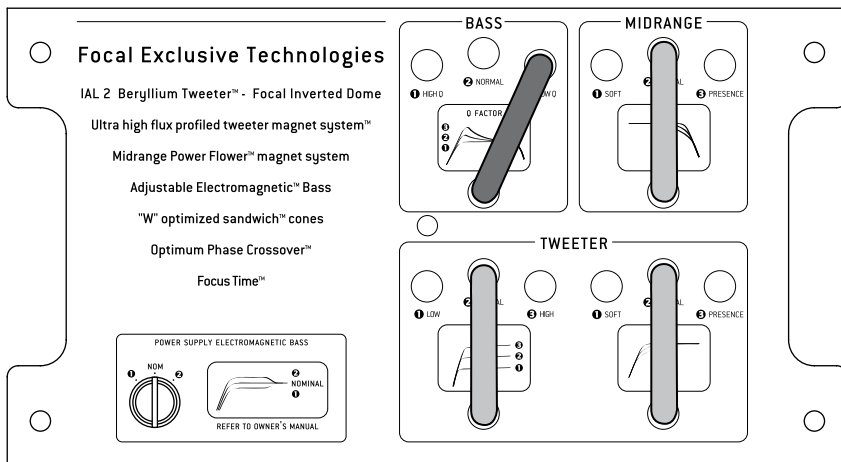

Obtained response in position 3.

Setting for:

- Normal room, but with the sub-bass band recessed due to cancelling standing waves.
- Plaster plate walls, absorbing the sub-bass band.
- Electronics sounding recessed in the LF band.

FINE TUNING

Bass section: quality factor setting (damping factor)

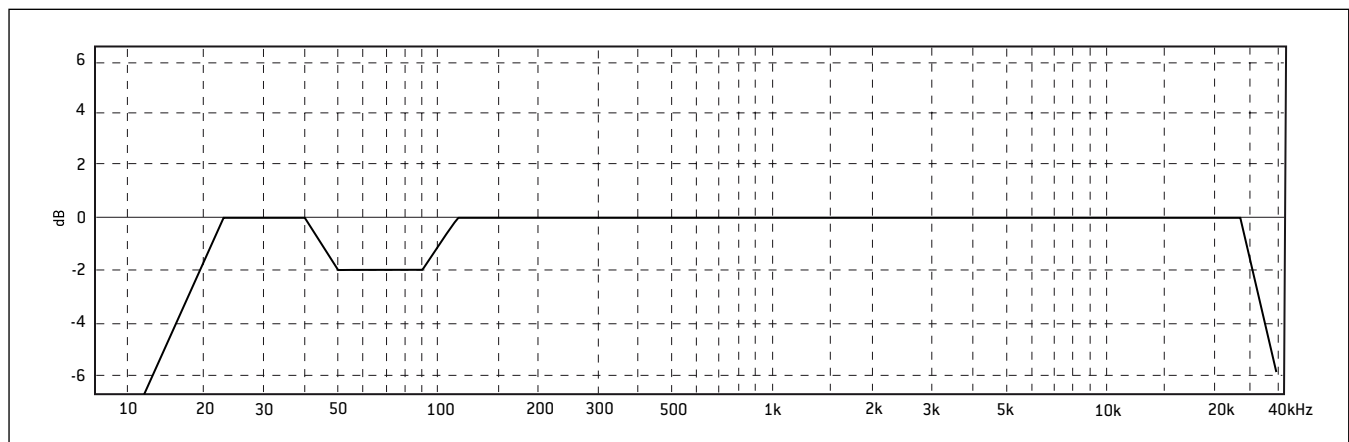
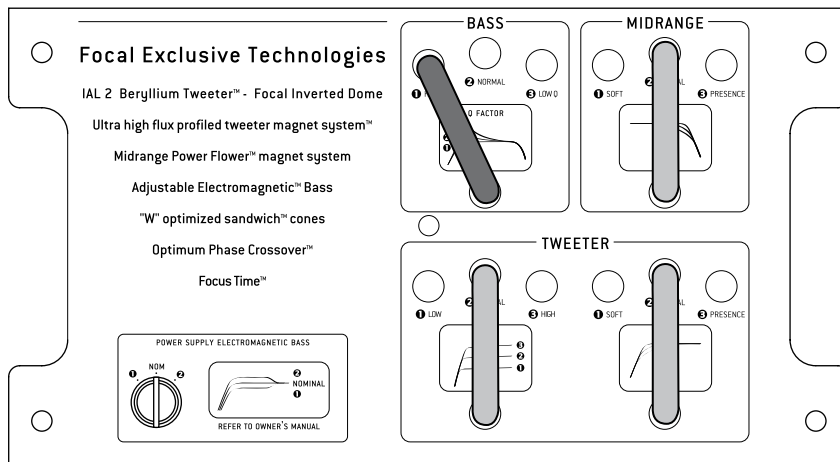

Obtained response in position 1.

Setting for:

- Normal room, hard walls (concrete, stone, ...).
- Electronics which excessively pushes up the sub-bass band.
- Cable sounding plain in the LF band.

FINE TUNING

Midrange & tweeter section : slope settings

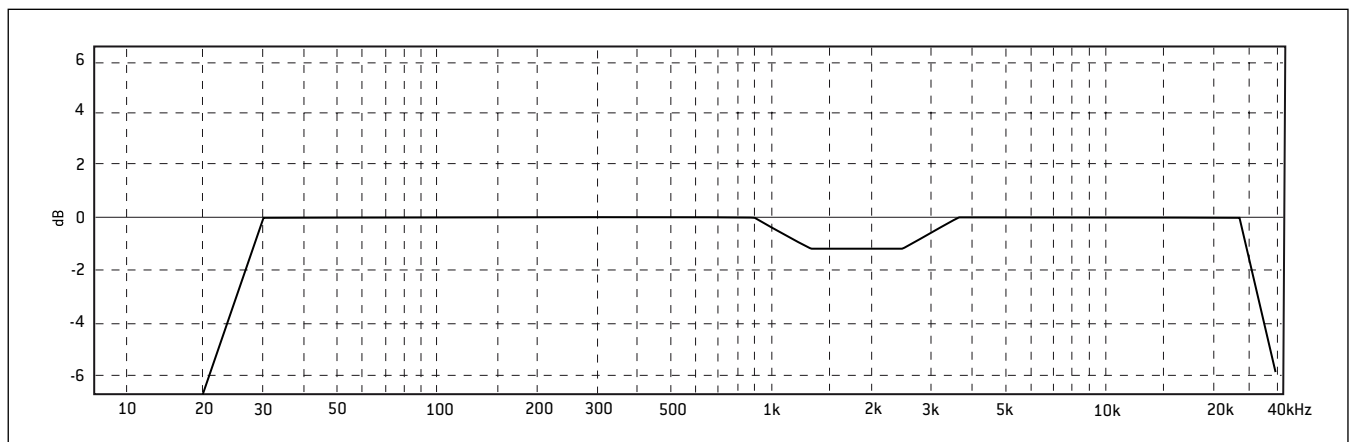
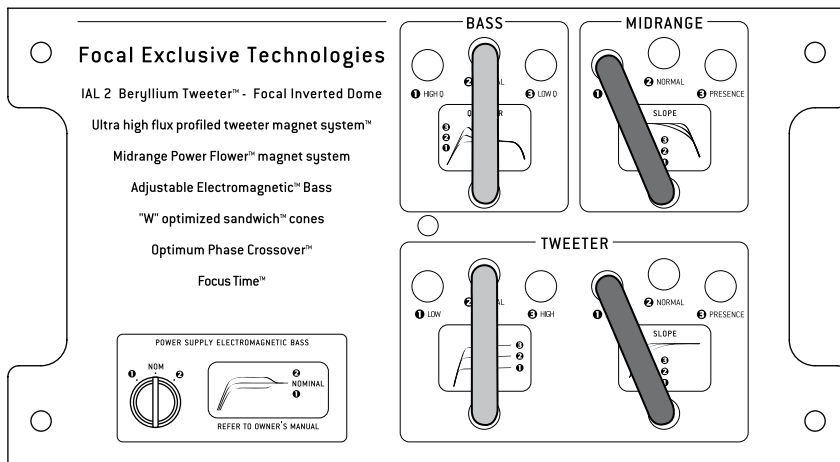

Obtained response in position 1: midrange/tweeter slope

Setting for:

- Normal room but with little damping, hard walls, big glass surface, tiled floor.
- Forward sounding electronics in the MF-HF band.

FINE TUNING

Midrange & tweeter section : slope settings

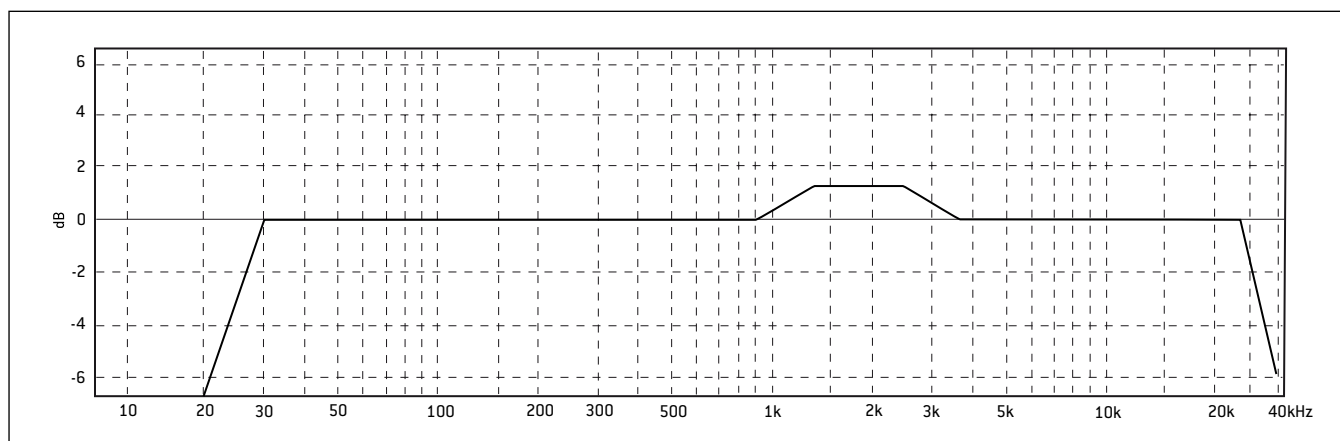
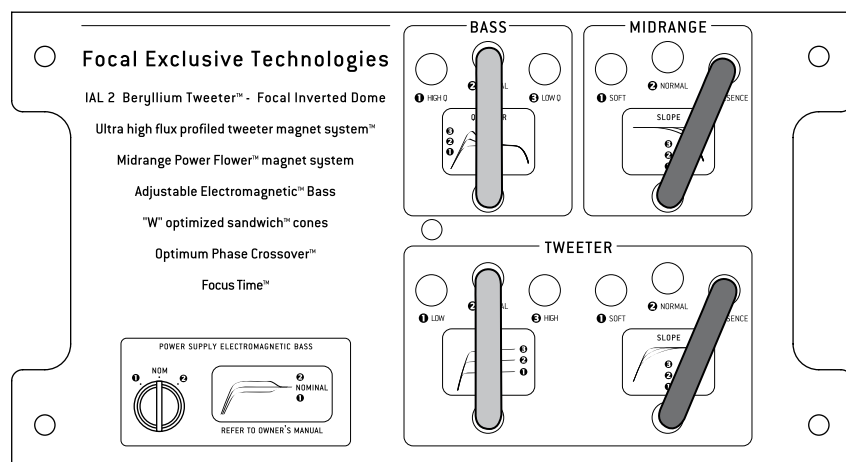

Obtained response in position 3: midrange treble

Setting for:

- Normal room but with little reflection, walls covered with paper or fabric, thick curtains, carpet or thick mat on the floor.
- Electronics with recessed MF-HF band.
- Smooth sounding cables.

FINE TUNING

Tweeter section : level settings

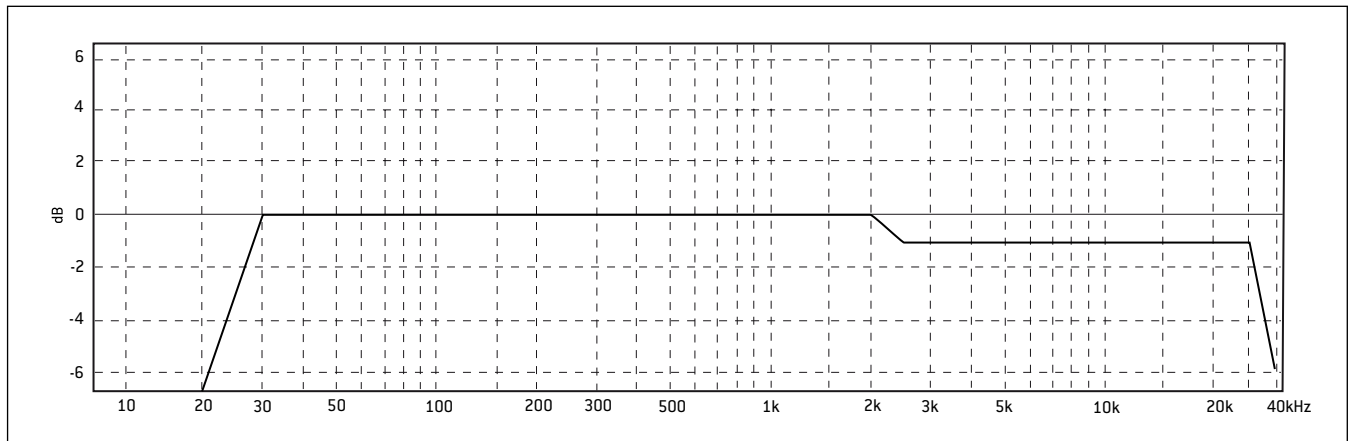
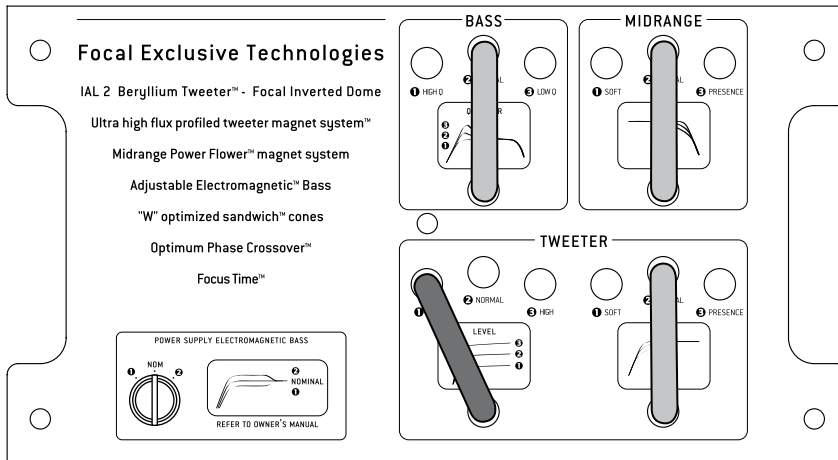

Obtained response in position 1 : treble

Setting for:

- Room with very little damping, glass surfaces and light curtains.
- Bright sounding electronics.
- Bright sounding cables.

FINE TUNING

Tweeter section : level settings

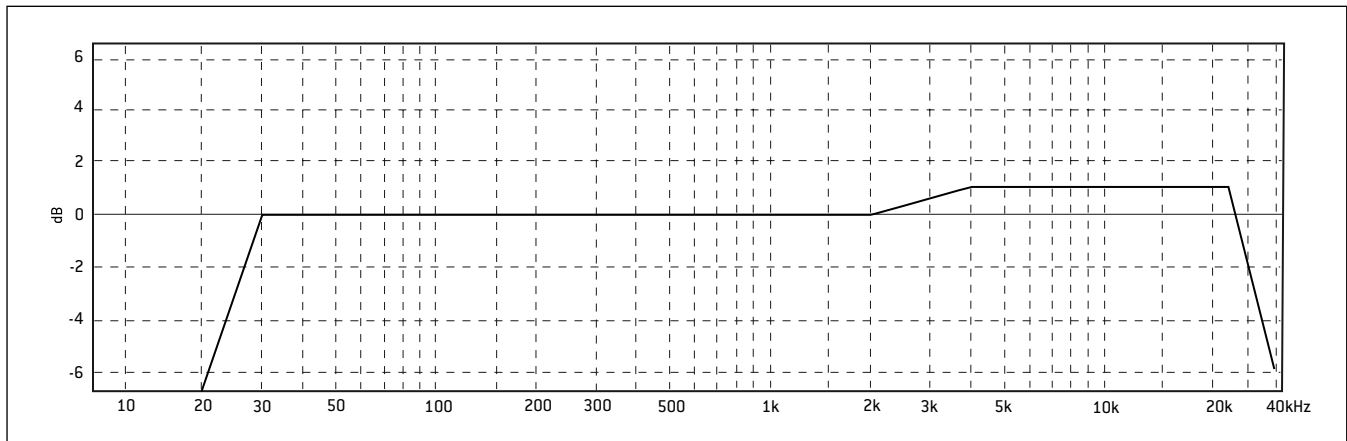
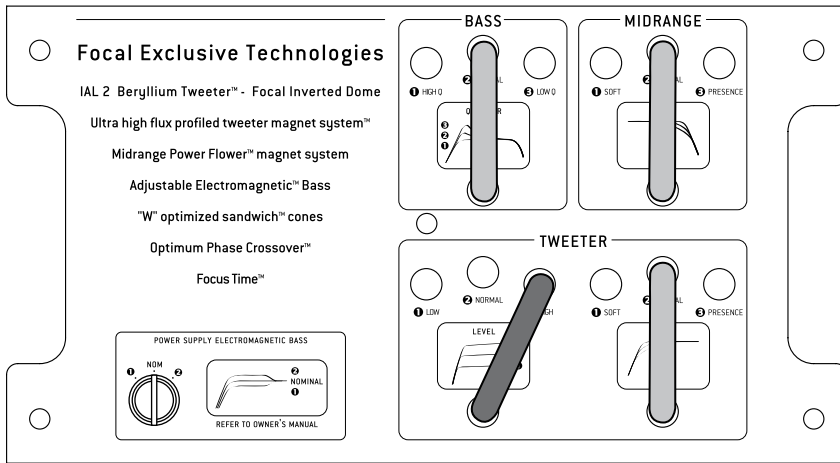

Obtained response in position 3: treble

Setting for:

- Highly absorbing room, thick curtains, fabric seats.
- Smooth electronics (tubes...).
- Wires with high electric capacity that reduces the HF band..

SPECIFICATIONS

Stella Utopia

Type	3-way, floorstanding bass-reflex loudspeaker
Drivers	Electro-Magnetic 13" (33cm) "W" woofer 2 Power Flower 6 ^{1/2} " (16.5cm) "W" midrange drivers IAL2 pure Beryllium inverted dome 1 ^{1/4} " (27mm) tweeter.
Frequency response (± 3 dB)	22Hz - 40kHz
Low frequency point (-6 dB)	18Hz
Sensitivity (2.83V/1m)	94dB
Nominal impedance	8 Ω
Minimum impedance	2.8 Ω
Crossover frequency	220Hz / 2 200Hz
Recommended amplifier power	50 - 1000W
Dimensions (H x W x D)	61 ^{1/3} x21 ^{3/4} x32 ^{11/16} inch (1558x553x830mm)
Net weight	363 lb (165kg)

Conditions of guarantee

All Focal loudspeakers are covered by guarantee drawn up by the official Focal distributor in your country.

Your distributor can provide all details concerning the conditions of guarantee. Guarantee cover extends at least to that granted by the legal guarantee in force in the country where the original purchase invoice was issued.



Your Focal-JMLab product was developed and manufactured with high-quality materials and components which can be recycled and/or reused. This symbol indicates that electrical and electronic equipment must be disposed of separately from normal garbage at the end of its operational lifetime. Please dispose of this product by bringing it to your local collection point or recycling centre for such equipment. This will help to protect the environment in which we all live.

MEMO

Standart Setting

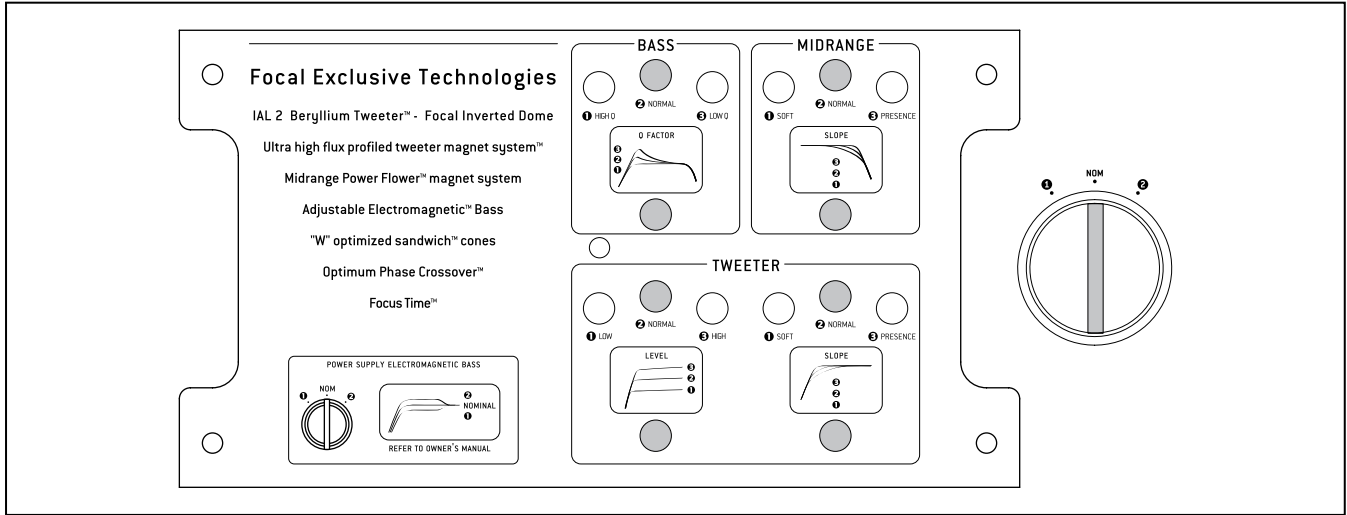

Check the locations of the settings made by your retailer as follow (here all in nominal position).

Setting day: _____ / _____ / _____

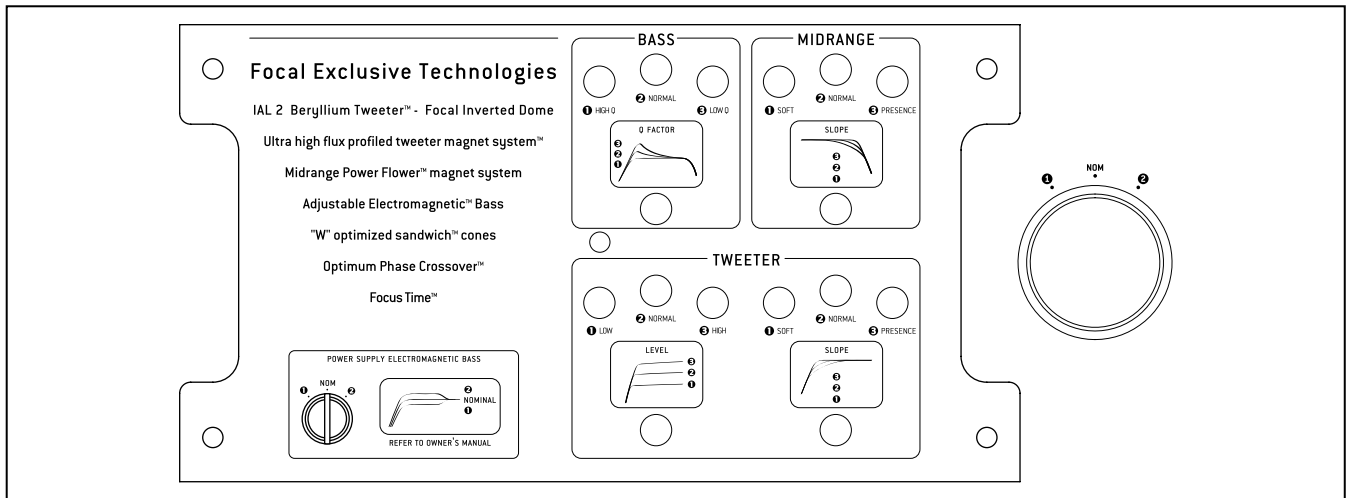

Notes:

.....

.....

.....

.....

MEMO

Setting day: ____/____/____

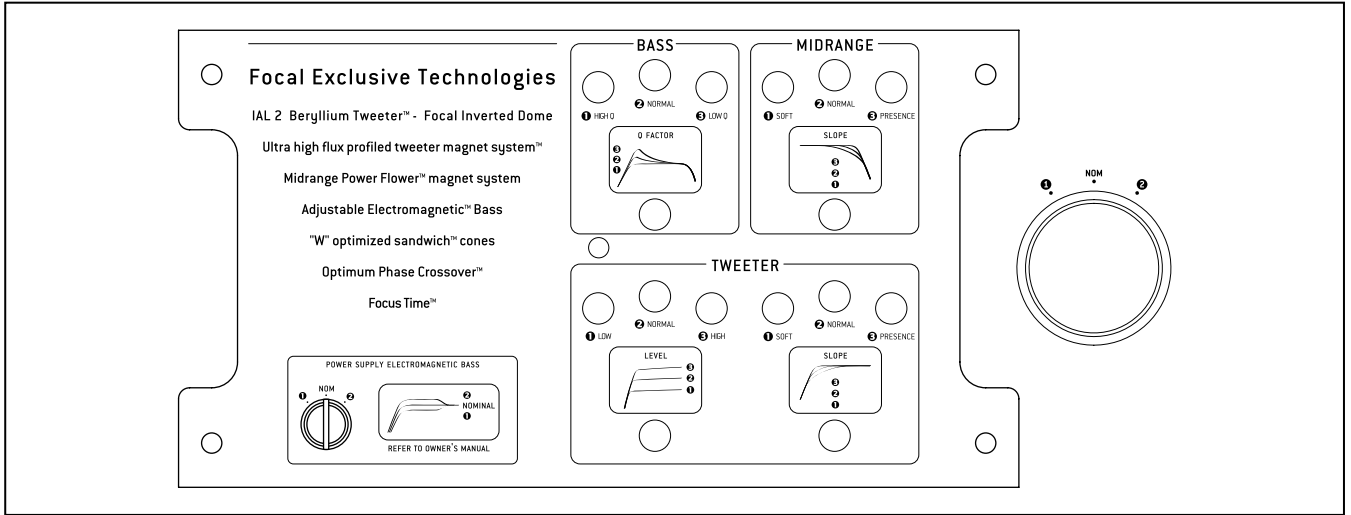

Notes:

.....

.....

.....

.....

Setting day: ____/____/____

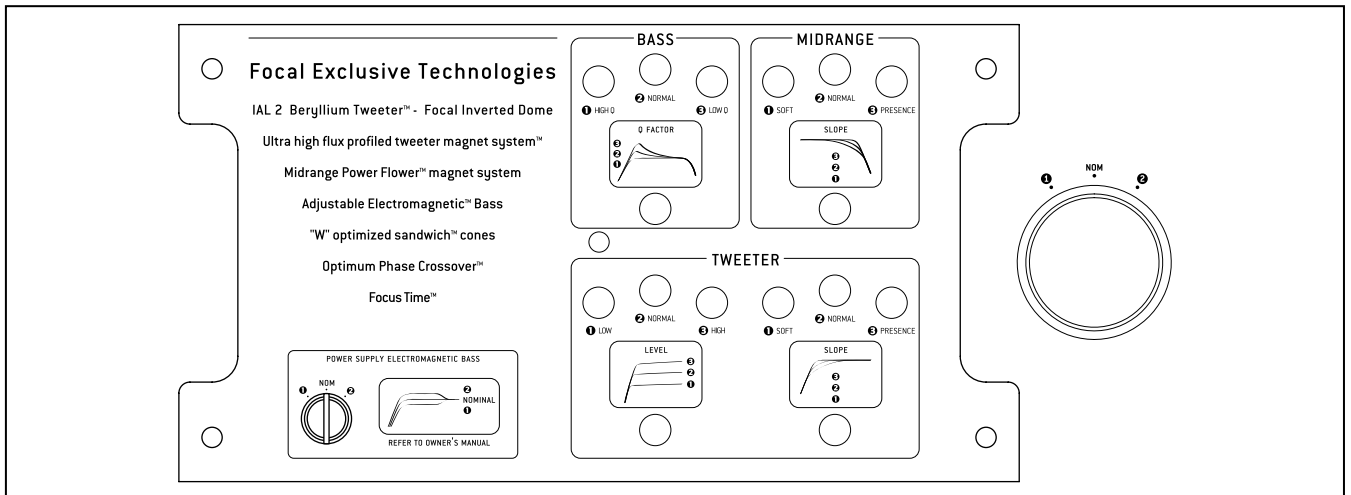

Notes:

.....

.....

.....

.....



CE

Focal-JMLab® - BP 374 - 108, rue de l'Avenir - 42353 La Talaudière cedex - France
Tel. (+33) 04 77 43 57 00 - Fax (+33) 04 77 43 57 04 - www.focal-fr.com

Printed on recycled paper by a French printing-house certified "Imprim'Vert".

INTERNATIONAL GUARANTEE

The Focal guarantee only applies if this page is returned to us within 10 days of purchase, to the following address:

Focal-JMlab - BP 374 - 108, rue de l'Avenir - 42353 La Talaudière cedex - FRANCE

Model: _____ Serial number: _____

Name of dealer: _____ Town: _____

Date of purchase: _____ Purchase price: _____

Your name: _____ Age: _____ Occupation: _____

Your complete address: _____

Your email address: _____

Details of your installation (brand, model):

■ CD / DVD recorder: _____ ■ CD: _____

■ Tuner: _____ ■ Satellite / cable: _____

■ DVD: _____ ■ Amp. Preamp. Receiver: _____

■ Other elements: _____

Your decision for purchasing this Focal model was made according to:

- | | |
|---|---|
| <input type="checkbox"/> Dealer's advice | <input type="checkbox"/> Friend's advice |
| <input type="checkbox"/> Visit to an exhibition, show | <input type="checkbox"/> Press article |
| <input type="checkbox"/> Listening in auditorium | <input type="checkbox"/> Already own Focal products |
| <input type="checkbox"/> Reliability / Quality | <input type="checkbox"/> Documentation |
| <input type="checkbox"/> Reputation | <input type="checkbox"/> French produce |
| <input type="checkbox"/> Guarantee | <input type="checkbox"/> Quality / Price ratio |
| <input type="checkbox"/> Design / Finishes | <input type="checkbox"/> Other _____ |
| <input type="checkbox"/> Sound | |

In case of purchase of new equipment, what were your former speakers ? _____

Explain in a few words why you choose Focal... _____

Further comments: _____

The information given on this page will remain confidential.

