

690 CA1

6" x 9" Access 1 coaxial (Aftersales Dpt ref: 6" x 9" CA1)

- Adjustable aluminum inverted dome tweeter
- All weather woven resistant glass fiber cone
- Voice coil cooling system



Specifications

Nominal power	75 W	
Maximum power	150 W	
Sensitivity	91 dB	
Cone	Braided glass fiber®	
Surround	Butyl	
Nom. impedance	4 ohms	
DC resistance	4 ohms	
VC diameter	30 mm	1-3/16 in
VC height	11 mm	7/16 in
Former	Kapton®	
Layers	2	
Wire	Copper	
Inductance		
Xmax	2.5 mm	1/16 in
Magnet d x h	90 x 15 mm	3-9/16x9/16 in
Magnet weight	0.4 kg	0.88 lb
Flux density	0.95 T	
Gap height	6 mm	1/4 in
Net weight	1.1 kg	2.42 lb

Parameters

Fs	54 Hz
Vas	25.79 l
Qts	0.86
Qes	1
Qms	6.51
Re	4.02 ohms
Sd	221 cm ²
Cas	1.85E-07 m ⁵ /N
Mas	46.97 kg/m ⁴
Ras	2448 ohms.ac
Cms	3.76E-04 m/N
Mms	23.08 g
Rms	1.203 kg/s
Ces	736.83 mF
Les	11.79 mH
Res	26.04 ohms
Bl	5.6 N/A
SPL	87.96 dB/W/m

Frequency Response / Impedance

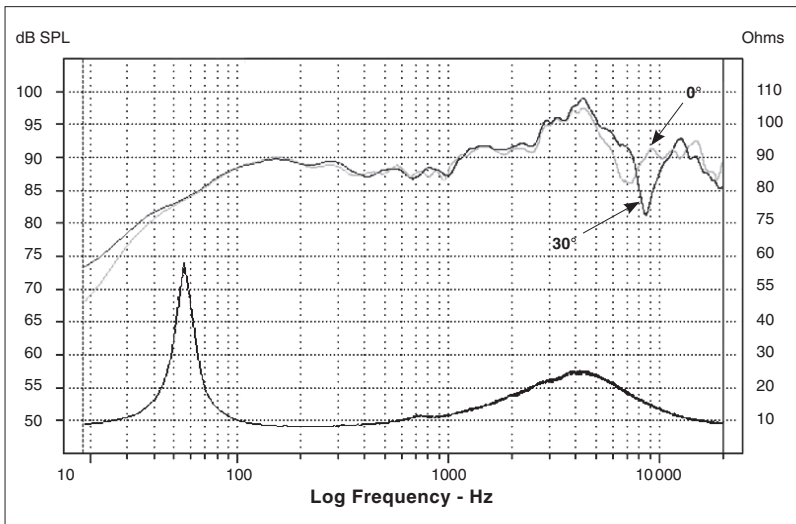

Suggested application

Load	V (l)	Fb (Hz)	F-3 (Hz)	Ql
Sealed	150	-	47	0.93
Sealed	-	-	-	-
Sealed	-	-	-	-

Mechanical Drawing

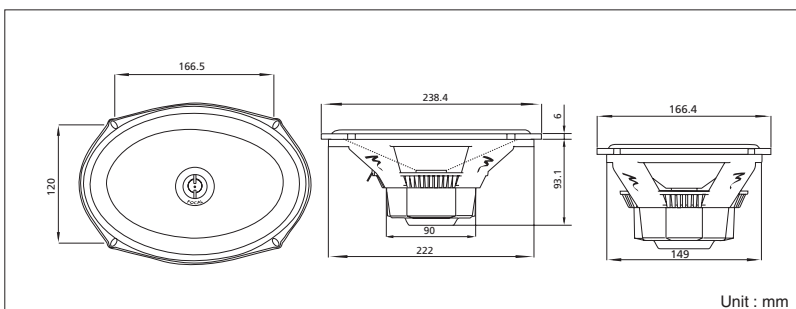

©Focal-JMlab - AS050926/2

Focal® is a trademark of Focal-JMlab® - BP 374 - 108, rue de l'Avenir - 42353 La Taubaudière cedex France - Tél. (33) 04 77 43 57 00 - Fax (33) 04 77 37 65 87 - www.focal-fr.com - SCAS051018/2



FOCAL
THE SPIRIT OF SOUND