

RIP LINE

250 S (700 Watts)

10" (250mm) high-power subwoofer for sealed box

SPECIFICATIONS

Nominal power	250W	
Maximum power	700W	
Sensitivity (2.83V/m)	88dB	
Cone	Polypropylene	
Surround	Rubber	
Nom. impedance	4 Ohms	
DC resistance	3.4 Ohms	
VC diameter	50mm	2"
VC height		
Former	Aluminum	
Layers	4	
Wire	Copper	
Inductance	0.58	
Xmax		
Magnet (dxh)	140x20mm	5.5x0.8"
Magnet weight		
Flux density		
Gap height		
Net weight		

PARAMETERS

Fs	42.14Hz
Vas	20.50 litres
Qts	0.63
Qes	0.71
Qms	5.69
Re	3.4 Ohms
Sd	301.72cm ²
Cas	1.46 ^E -0.7m ⁵ /N
Mas	97.77kg/m ⁴
Ras	4549.34 N/A
Cms	160µm/N
Mms	89g
Rms	4.141kg/s
Ces	791.71mF
Les	17,93 mH
Res	27.01 Ohms
BI	10.58 N/A
SPL	85.2dB



KEY POINTS

- 2" (50mm) 4-layer voice-coil on aluminum former
- High excursion rubber surround
- Reinforced polypropylene cone
- Rigid metal basket
- Chrome magnet
- 5.5 x 0.8" (140x20mm) magnet
- Screw binding post terminal
- Subwoofer optimized for sealed box

FREQUENCY RESPONSE

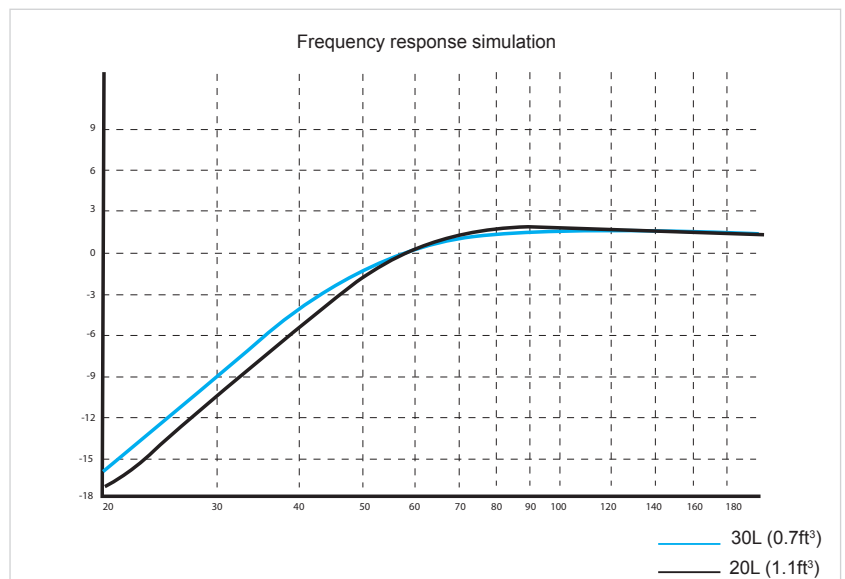

MECHANICAL DRAWING

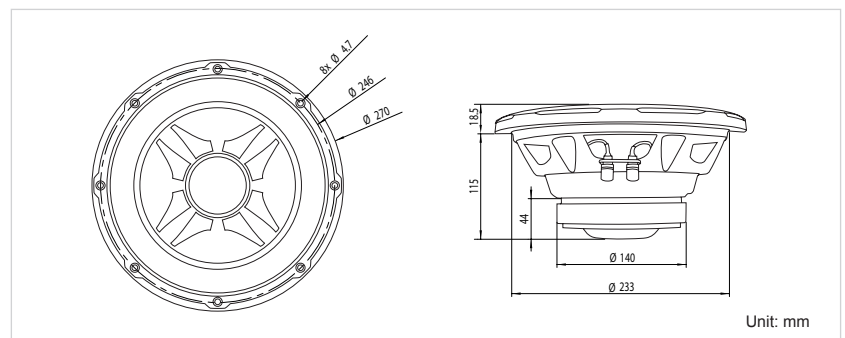

Unit: mm

