

21 V2

210mm Polyglass subwoofer



- Zamak chassis
- Polyglass cone, Butyl surround
- High power handling



Specifications

Nominal power	200 W	
Maximum power	400 W	
Sensitivity	85 dB	
Cone	Polyglass	
Surround	Butyl	
Nom. impedance	4 ohms	
DC resistance	3.5 ohms	
VC diameter	50 mm	1 15/16 in
VC height	25 mm	1 in
Former	Aluminium	
Layers	2	
Wire	Copper	
Inductance	1.27 mH	
Xmax	9 mm	
Magnet d x h	115 x 25 mm	4 1/2 x 1 in
Magnet weight	2500 g	5.51 lb
Flux density	0.8 T	
Gap height	8 mm	5/16 in
Net weight	3.5 kg	7.71 lb

Suggested Application

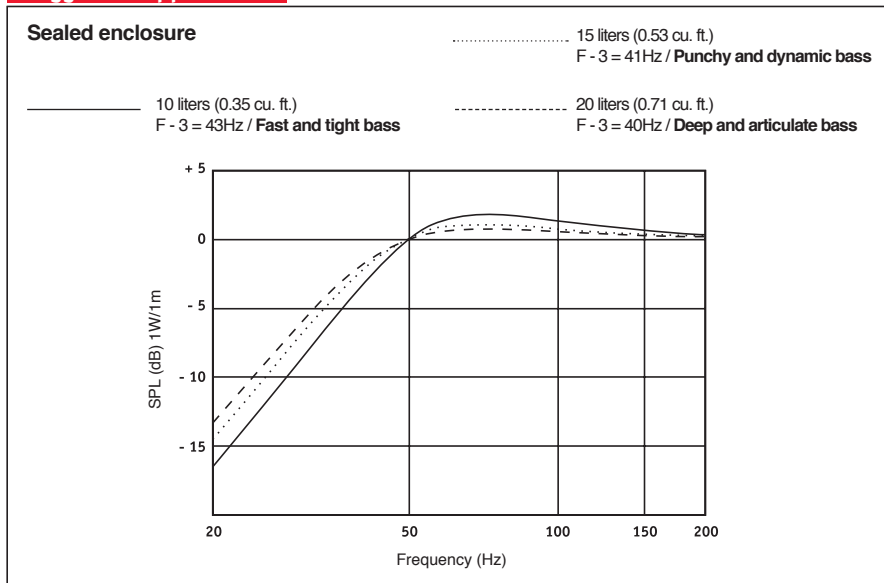

Parameters

Fs	36.50 Hz	
Vas	15,31 l	0.541 Ft ³
Qts	0.68	
Qes	0.86	
Qms	3.28	
Re	3.5 ohms	
Sd	188.69 cm ²	29.24 in ²
Cas	1.09E-07 m ⁵ /N	
Mas	174.47 kg/m ⁴	
Ras	12 198.99 ohms.ac	
Cms	3.06E-04 m/N	
Mms	62.12 g	0.13 lb
Rms	4.343 Kg/s	
Ces	1071.41 mF	
Les	17.75 mH	
Res	13.35 ohms	
Bl	7.61 N/A	
SPL	81.21 dB/W/m	

Mechanical Drawing

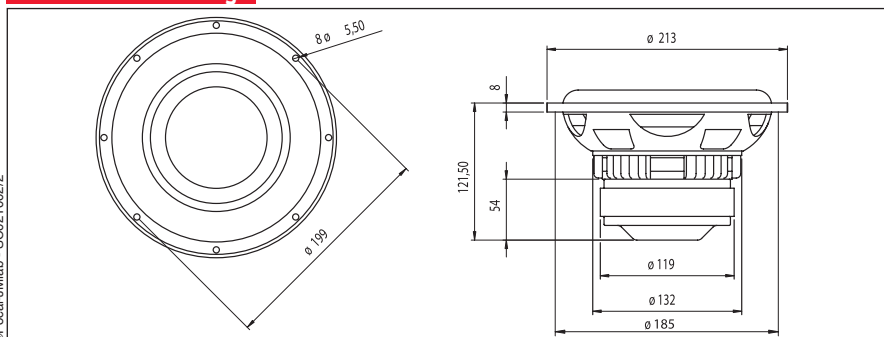

Suggested application

Load	V (l)	Fb (Hz)	F-3 (Hz)	Ql
Vented	-	-	-	-
Sealed	-	-	-	-

Focal® is a trademark of Focal-JMLab®