

130 CVX

5" Polyglass woofer

- Built-in audiophile crossover
- Polyglass cone
- Adjustable inverted dome tweeter



Specifications

Nominal power	50 W	
Maximum power	100 W	
Sensitivity	91 dB	
Cone	Polyglass	
Surround	Butyl	
Nom. impedance	4 ohms	
DC resistance (in parallel)	3.36 ohms	
VC diameter	25 mm	1 in.
VC height	11 mm	7/16 in.
Former	Kapton®	
Layers	2	
Wire	Copper	
Inductance		
Xmax	2.5 mm	1/16 in.
Magnet (d x h)	85x15mm	3-1/3x9/16 in.
Magnet weight	0.3 kg	0.66 lb
Flux density	1.1T	
Gap height	5.5 mm	3/16 in.
Net weight	0.85 kg	1.87 lb

Parameters

Fs	70.16 Hz
Vas	13.22 l
Qts	0.55
Qes	0.59
Qms	8.13
Re (in parallel)	3.36 ohms
Sd	132.73 cm ²
Cas	9.4E-08 m5/N
Mas	54.66 kg/m4
Ras	2936.82 ohms.ac
Cms	5.34E-04 m/N
Mms	9.63 g
Rms	0,522 kg/s
Ces	398.33 mF
Les	12.92 mH
Res	46.3 ohms
BI	4.92 N/A
SPL	86.8 dB/W/m

Suggested Application

Sealed enclosure

0° and 30° frequency response

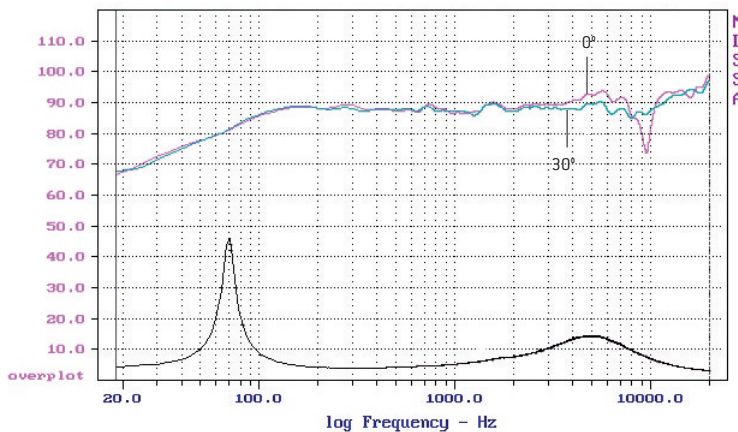

Mechanical Drawing

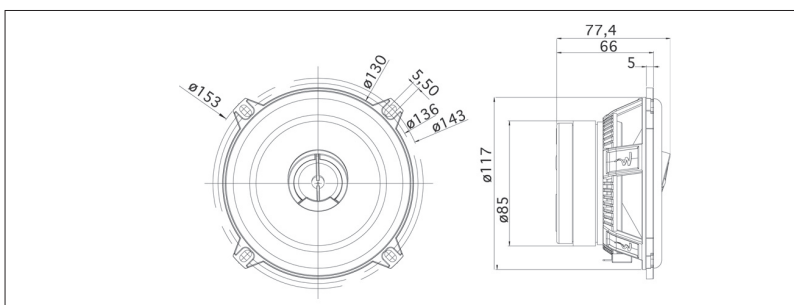

Suggested application

Load	V (l)	FB (Hz)	F-3 (Hz)
Sealed	30	-	76

