

ELECTRA 1000 Be® stand mounting

Montage pied ELECTRA 1000 Be®

User manual / Manuel d'utilisation

• Accessories per stand

Accessoires par pied

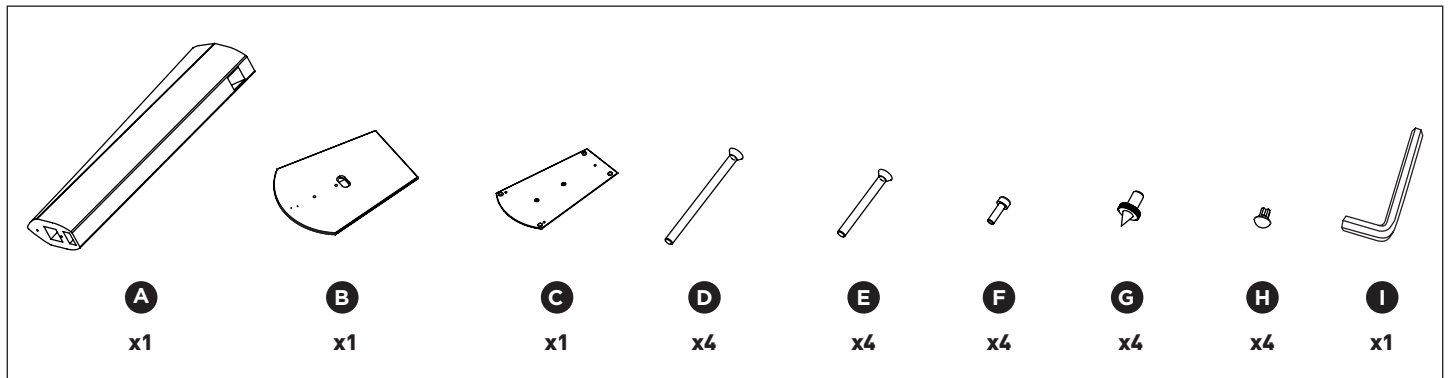

• Fixing of the parts

Fixation des éléments

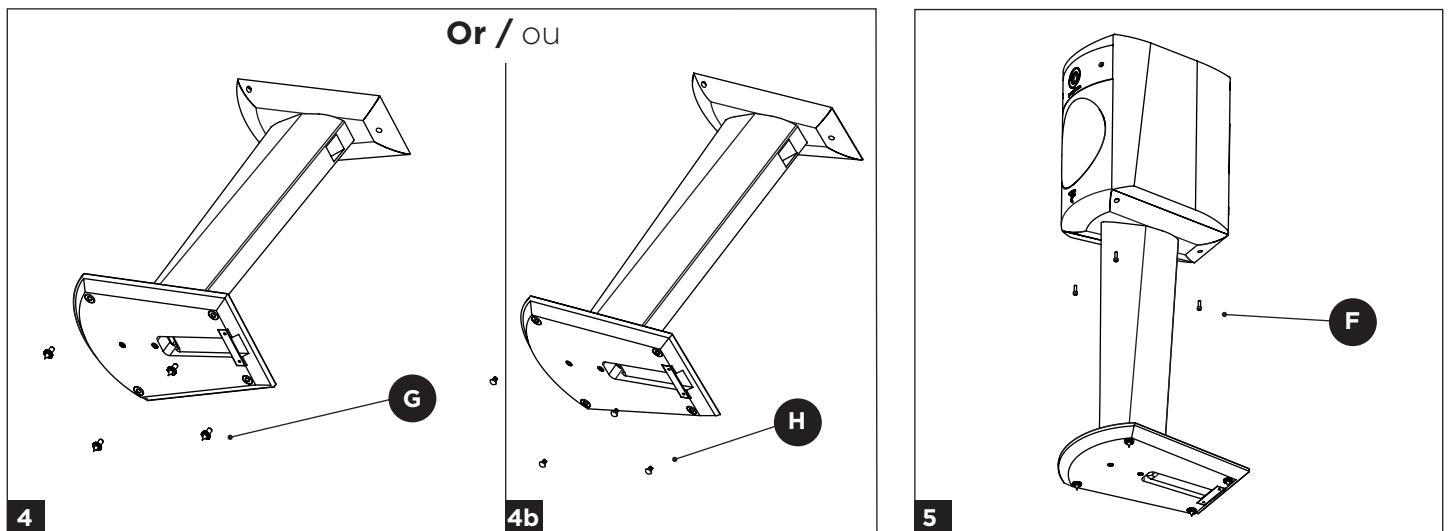
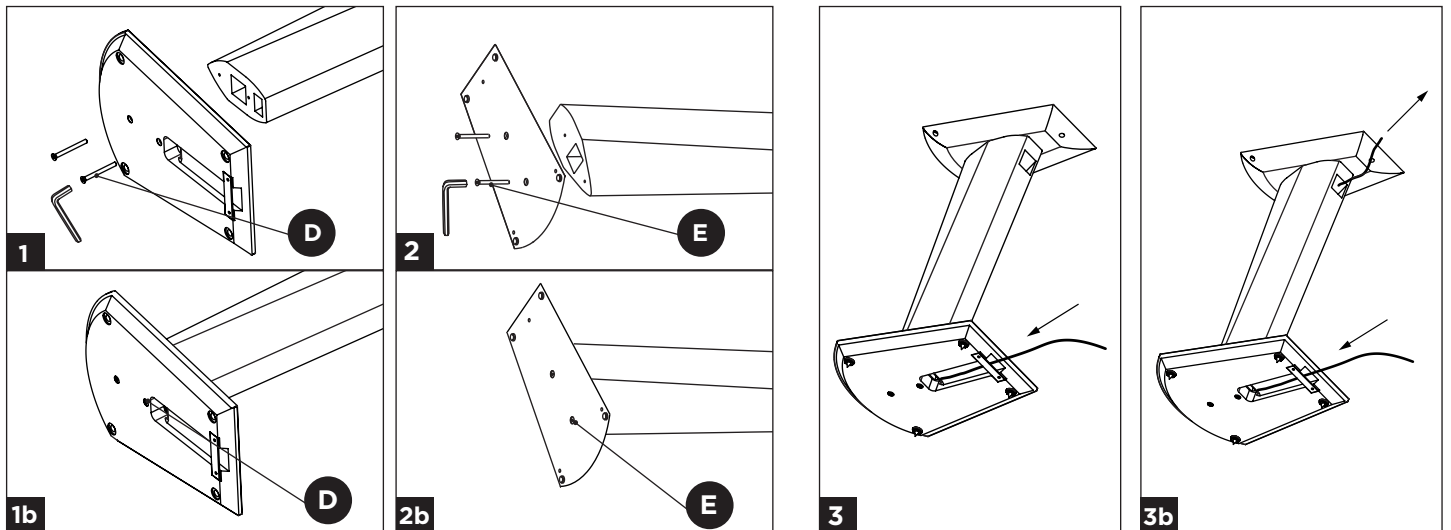

Focal-JMLab® - BP 374 - 108, rue de l'Avenir - 42353 La Talaudière cedex - France - www.focal.com - Tel. (+33) 04 77 43 57 00 - Fax (+33) 04 77 43 57 04



SCAA-171123/2 - codo 1410

Due to constant technological advances, Focal reserves its right to modify specifications without notice. Images may not conform exactly to specific product. Dans un but d'évolution, Focal-JMLab se réserve le droit de modifier les spécifications techniques de ses produits sans préavis. Images non contractuelles.